

Welcome to Aero-modeling using Paper Wings!

Paper Airplane models for college students!

This may look ridiculous and appear to be a child's play. As you use the kit and build your first plane, you will realize that it is not all that simple. Soon you will learn to make the plane to fly and discover the joy of flying. In the process you will learn the nuances of flying intuitively.

This document will provide you with the essential hints to make the planes and fly them. Follow the guidelines and experience the joy of flying.

At the divisional level, you will be expected to design your own Paper Wing plane. In the finals you will be expected to fly a radio controlled plan and conduct a reverse-engineering. Successful fabrication and flying of Paper Wings at this level will form a strong basis for higher level competitions as explained above.

Contents

1. **Assembly Instructions** [page 2](#)
 - Tools and materials
 - Airplane parts
 - Cutting out the parts
 - Gluing
 - Finishing touches
2. **Flight Instructions** [page 7](#)
 - Test flight
 - Achieving altitude
 - How to catch rising air currents
 - Repairs
 - Storage
 - Enjoy displaying your airplanes
 - Transporting your plane safely
3. **Introduction to Paper Plane Design** [page 17](#)
 - How to make your plane fly well
 - How to improve flying performance
 - How to improve stability
 - Elementary design method
4. **How to build Paper Wings** [page 28](#)
 - How to assemble the most wings
 - Racer 520 Amelia
 - Racer 521 Jacqueline

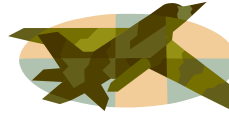

1. Assembly Instructions

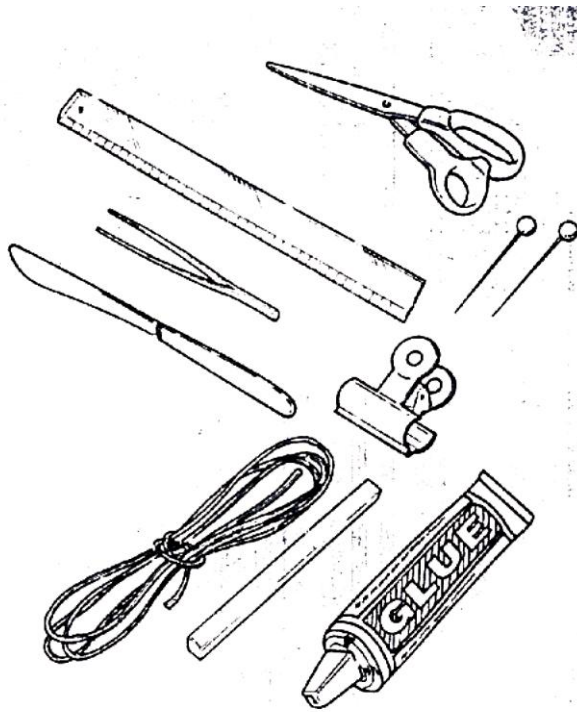

Tools and materials

Scissors

A pair of scissors that cuts well.

Ruler

Used to fold pieces and make creases accurately

Common ordinary table knife

Used for making the creases in triangular long fuselage

Clips

Approximately 10 clips are required for the construction of the triangular long fuselage.

Tweezers

Used for checking the centre of gravity and assembling the smaller pieces

Glue

A clear fast drying glue is most suitable.

Rubber band and rod

Used for making a rubber band catapult

Straight pin

Used for making pin holes

Airplane parts

Figure shows a planes parts and what they are called

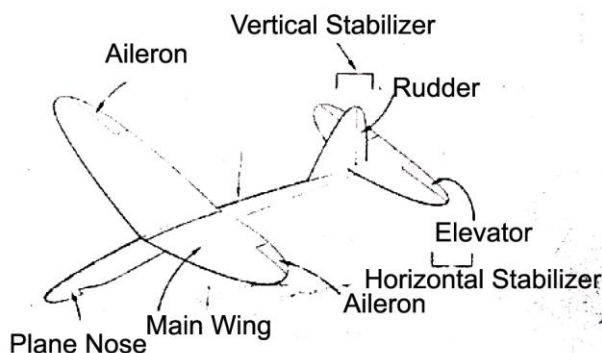

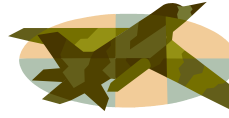

Cutting out of the parts

Roughly cut out each piece taking care not to cut into adjacent pieces

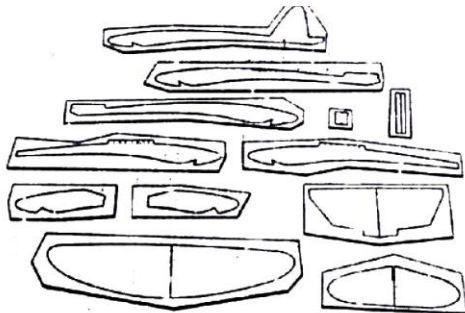

First Roughly cut out all the pieces

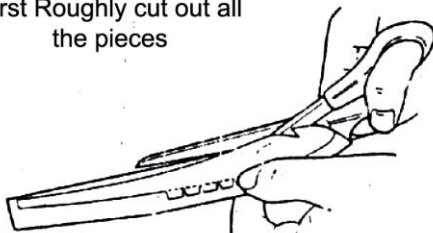

Cut precisely on the lines

Hold a ruler along the dashed line to help you fold accurately

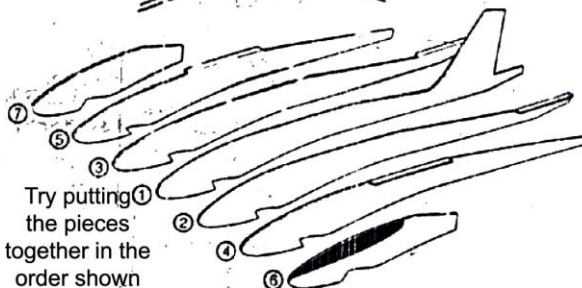
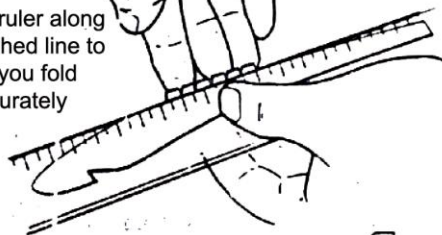

Try putting the pieces together in the order shown before assembly

Trim each piece to size by cutting precisely on the line. However, don't cut on the lines of the front and back of the main wing backing, leave a 2-3 mm margin on these edges as described in the gluing instructions.

Bend the tabs for the main wing and stabilizer before gluing the fuselage (plane body) together. Bend the tabs along the dashed lines using a ruler to make sure that tabs are neatly folded.

Gluing

Try putting the pieces together before gluing according to the gluing instructions and explanatory figures for each model, to make sure everything is ready and in order.

After all the details have been satisfactorily worked out, you are not ready for the actual gluing. Following the gluing instructions precisely glue the pieces together in the proper order.

(Note : To build a straight solid body, first glue (1), (2) and (3) together and let dry on the flat surface. Then glue the rest of the body parts, in order to this center section

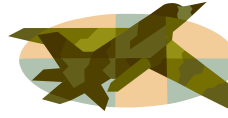

Paper Wings Guidelines

Spread glue evenly over the entire surface to be glued

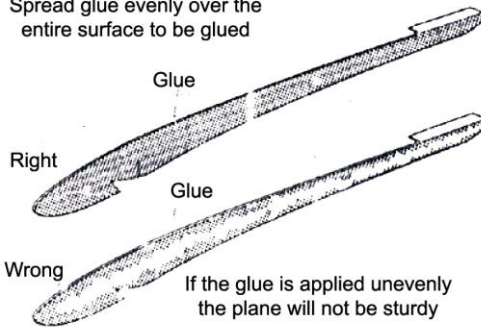

Place the glued parts inside a folded sheet of paper to press out the excess glue

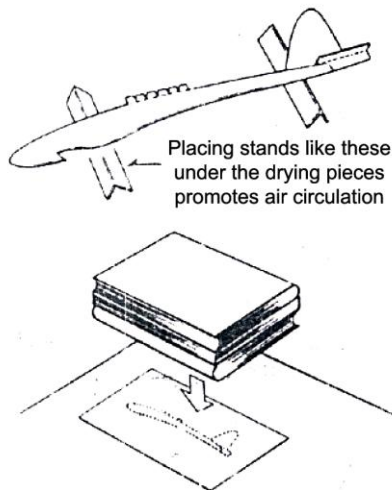
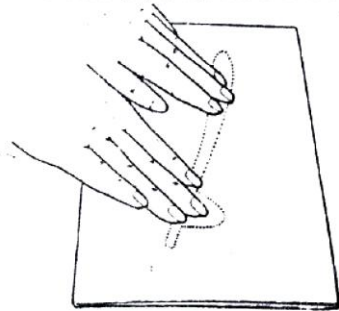

Placing stands like these under the drying pieces promotes air circulation

Apply the glue evenly and quickly, making sure that the assembled pieces do not slip out the position

If the glue is insufficient the pieces will not be firmly glued together, resulting in weak construction and poor flying performance.

In order to assemble a sturdy fuselage, after gluing, on each piece, place, the assembled pieces inside a folded piece of scrap paper and press out the excess glue with your fingers. Gradually assemble the fuselage piece by piece in this fashion, taking care that none of the pieces have slipped out of place and that each one is in its proper position.

Use a blank piece of scrap paper and make sure that no print on the paper comes into contact with the glued parts. Since glue has the power to dissolve printing ink, the ink could smear onto the assembled plane.

Spread several layers of large scrap paper over a desk or other flat surface for protection. Set the newly glued main wing and fuselage on the papers to dry for at least 5 to 6 hours.

On for speedier drying, place "stands" of folded paper under the glued parts as shown in the figure. This permits improved air circulation to the underside of the glued parts.

When building a layered fuselage, it is helpful to place books on top of the fuselage as a weight after gluing in order to maintain a solid and uniform body.

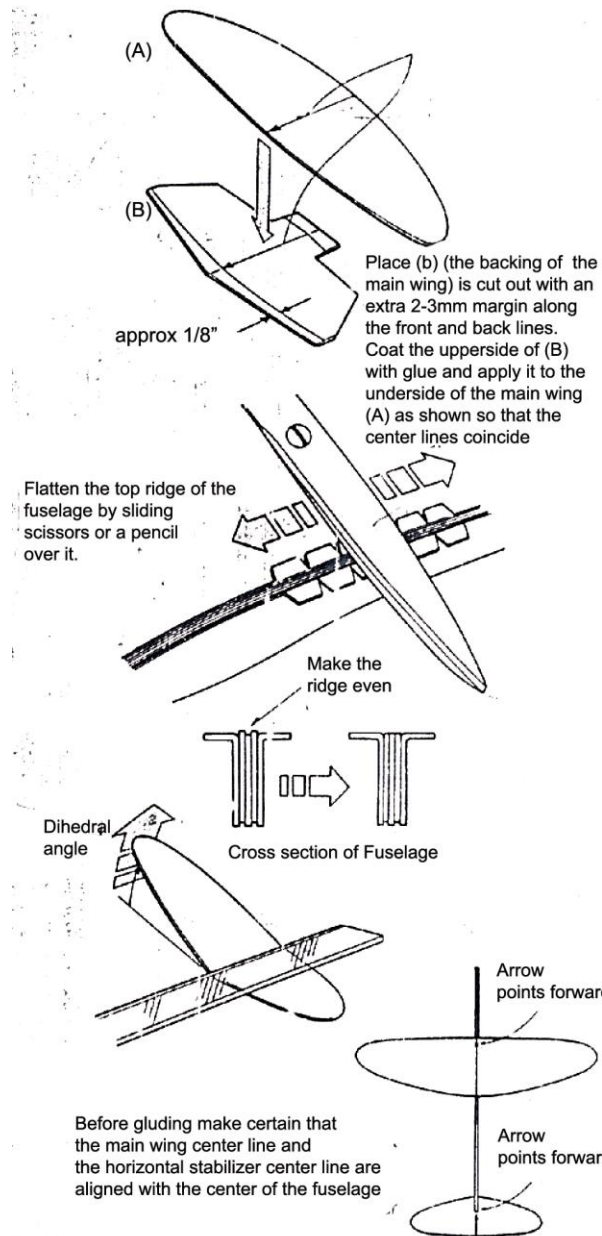
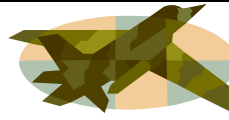

When assembling the main wing is mentioned we are referring to gluing the reinforcement piece (B) to the main wing (A)

The center line for piece (B) extends about 3mm (1/8") in front and in back of the cutting lines when cutting out piece (B) you will notice in the figure that the left and right edges are cut right on this lines, but the front and back edges extend 2 – 3 mm outside the lines. Apply glue evenly to the upper surface of piece (B) and gently fix piece (A) on top of piece (B). Because piece (b)'s center line extends out from the front and back of piece (A), it is easy to line up the center lines of pieces (A) and (B) accurately. After the glue is dry, you can cut off the protruding portions of piece (B).

In order to glue the main wing precisely and securely to the body, the part of the fuselage to which it will be glued must be smoothed flat with scissors or a pencil, before applying glue, as shown in the figure.

Place a ruler along the center line of the main wing, and bend the wing slightly upward (called a dihedral angle) as shown in the figure. Since the dihedral angles vary from model to model, bend the wing upward until the angle is identical to the angle indicated in the assembly instructions for the particular model

When gluing the main wing and horizontal stabilizer to the fuselage, make sure that the center line is properly aligned lengthwise with the center of the fuselage. You will find that if you glue the stabilizer onto the fuselage before gluing the main wing onto the fuselage, assembly will be much easier.

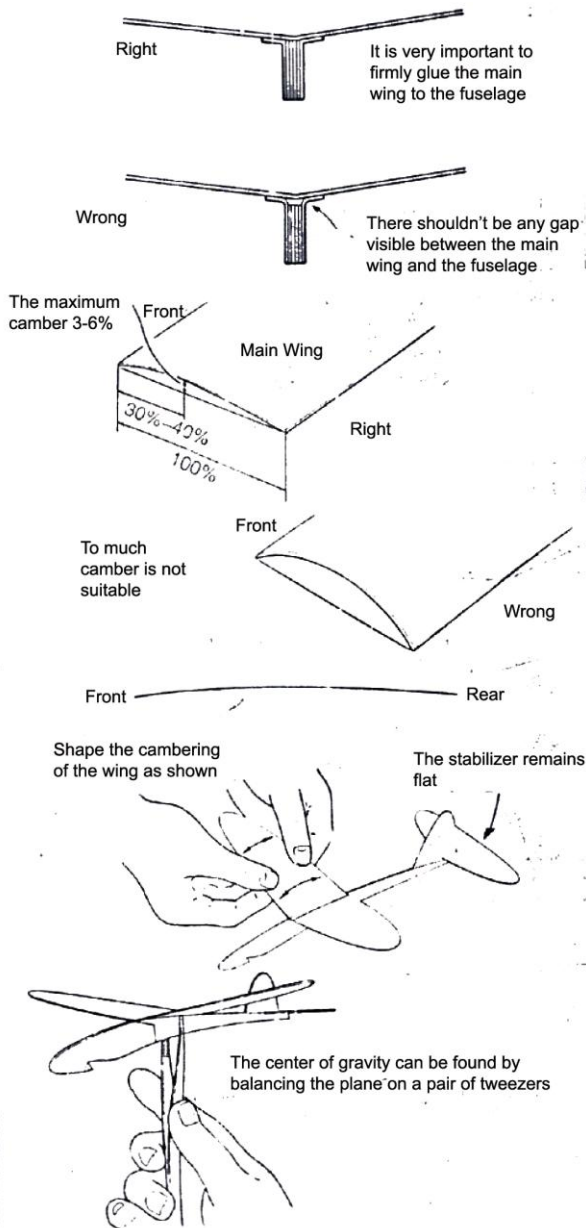
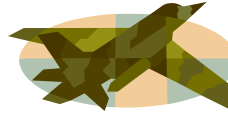

The importance of gluing the main wing firmly to the fuselage cannot be overemphasized. In order not to leave any gap between the main wing and the body, press down firmly on the center of the main wing about 5 – 6 minutes after gluing. After gluing the main wing and stabilizer onto the fuselage, let it dry thoroughly for 3 – 4 hours.

Finishing Touches

To make a truly high performance plane, it is important that the cross section of the main wing be curved in such a fashion as to minimize drag, or air resistance, and maximize lift, the upward draft of air.

To make the proper curve, bend the main wing slightly in the manner shown in the figure (this is called cambering the wing). This shape is necessary for top performance.

Use the figure on the right as a guide to give an appropriate camber to the main wing.

The maximum camber point should be between a distance of 30% and 40% from the front edge of the main wing.

Only the main wing is to be cambered. The stabilizer should be left flat.

Placing the dihedral angle gauge on the middle of the wing, once again make sure that the dihedral angle is the required one.

To test to see if the center of gravity is properly aligned or not, take an open pair of scissors or tweezers and balance the plain on the two tips at the mark as shown in the figure.

All the planes in the Heritage series are designed to have the center of gravity located at the mark. In some cases, however, due to an excess of glue or lacquer on the plane, you may find that the center of gravity is not properly located at the

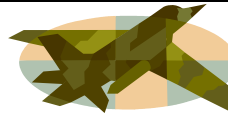

Adjusting the location of the center of gravity

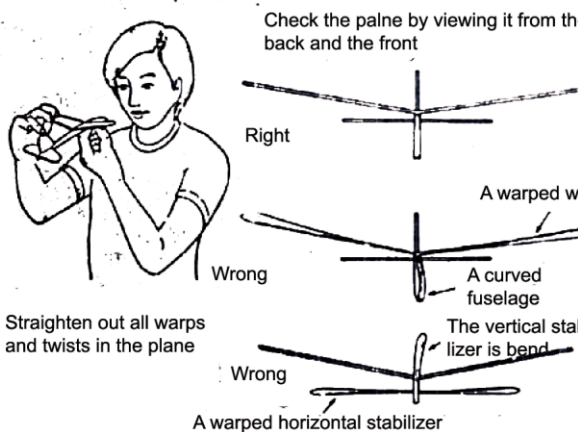
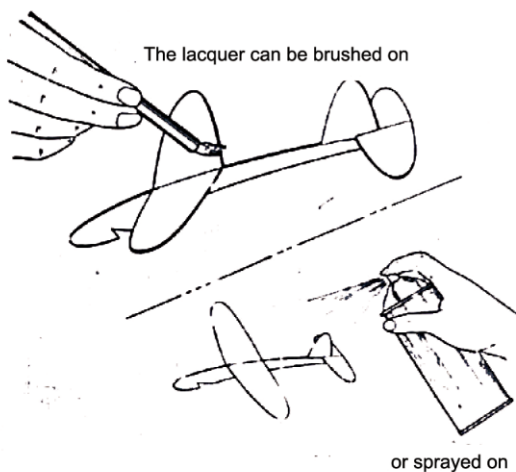
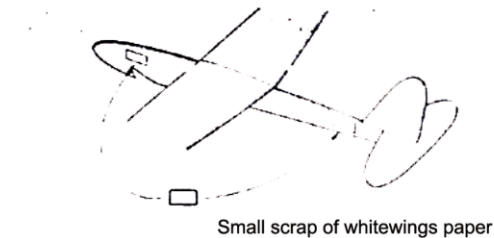

mark. When this

Happens, it becomes necessary to add some additional weight. To do so, attach a small scrap of the remaining white wings paper lightly to either side of the plane nose or the rear of the fuselage and secure it temporarily with a small amount of glue. Vary the position or size of the attached paper until the center of gravity is located properly and then glue the attached paper firmly to the fuselage. The center of gravity should be located within 1 mm (1/24") of the mark.

If your paper plane is coated with lacquer, it will become water resistant. Therefore when it lands on wet grass, if you quickly wipe the water off with a soft cloth, you are ready for another flight for preserving the beauty of the white paper, clear lacquer is good, but if you want your plane to be a different colour, you can use colored lacquer. It doesn't matter whether you spray it on or paint it on with a brush, but in order to keep the plane light and preserve its balance and center of gravity, be careful to coat the plane as thinly and evenly as possible.

2. Flight Instructions

One of the secrets of flying a paper plane well is to view the plane closely from ahead on position and straighter out all warps, bends or twists with your fingers.

Inspect your plane thoroughly from the front:
(1) Is the fuselage bent?

(2) Are both the right and left main wings straight, perfectly matched and are both inclined at the same angle?

(3) Is the horizontal stabilizer warped or bent?

(4) Is the vertical stabilizer warped or bent?

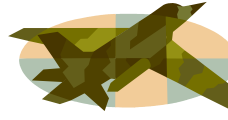

Side view of the plane

If the main wing is not warped, the edges of the left and right wings should be parallel.

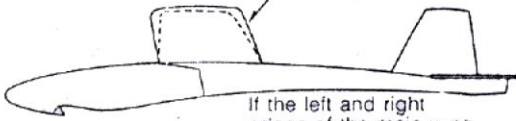

If the left and right edges of the main wing are not parallel, this is proof that the wings are warped.

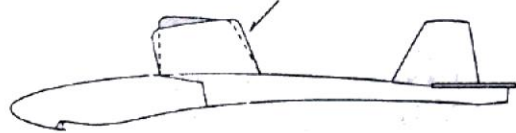

Check for these irregularities and straighten out any bent or warped area gently and carefully.

Inspect your plane from the rear and check for irregularities in the same manner as above.

Check the plane from both sides also

- Do the inclinations of both the near and far wing tips match?

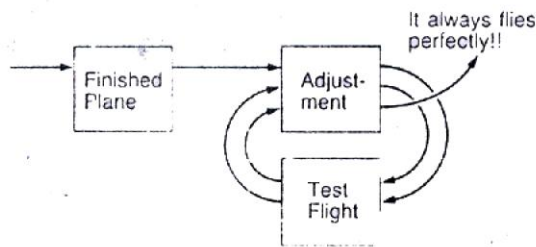

Test Flight

The reason most model airplanes don't fly well is that they have not been properly adjusted. After finishing your plane, the importance of following the test flight and adjustment instructions carefully cannot be overemphasized!!

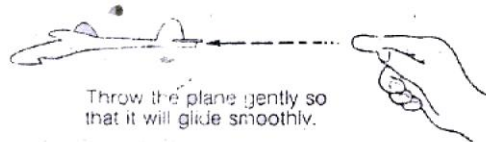

If you continuously repeat the test flight and adjustment procedures, adjusting your plane slowly but surely. You will finally arrive at a point where your plane will always glide smoothly and in a straight line. A perfect flight every time!

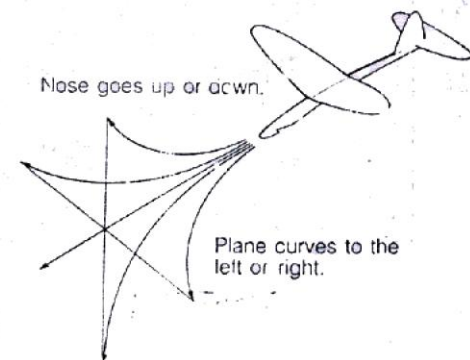

Try to test fly your plane when there is as little wind as possible. If there is breeze, always through your plane straight into the wind. When test flying your plane indoors, always try to throw it toward a curtain to ensure safety.

Do not throw the plane upward. Aim it horizontally or slightly downward and toss it gently forward to make the plane glide smoothly.

How to adjust your plane: When it curves to the left or right and When the nose goes up or down

If you know how to adjust your plane to correct these two faults, your plane will be able to fly

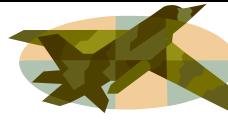

well. I will explain how to correct each of these faults with the proper adjustment.

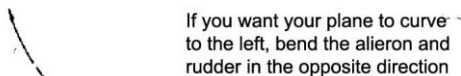
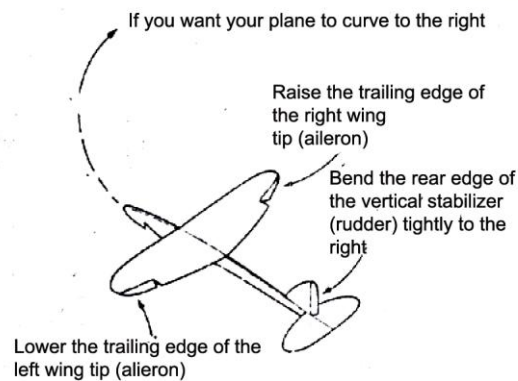

When the back part of the horizontal stabilizer (elevator) is bend upward the plane's nose will always tend to point up

When the back part of the horizontal stabilizer (elevator) is bend upward the plane's nose will always tend to point up

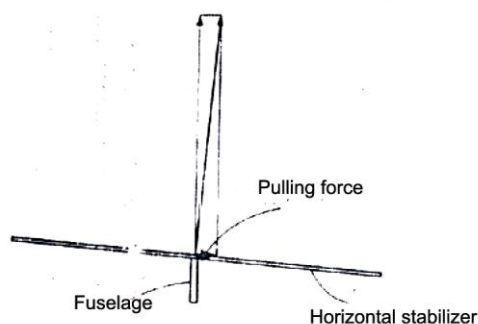

The First thing to look for when test flying your plane is whether it flies to the left or right. If so perform the following adjustments and your plane will fly straight.

If a paper plane curves to the left or right, it is always because there is a bend or a warp somewhere on the plane. Therefore, the first step is to examine the plane again thoroughly and straighten out the affected parts with utmost care. If the plane still curves to the left or right, bend the trailing edges of the wing tips (ailerons) and vertical stabilizer (rudder) in the appropriate directions, according to the instructions in the figure on page 13, in order to correct this fault and ensure straight flight.

The second thing to test for is to see whether or not the nose gradually goes up and the plane loses speed also watch if the plane's nose rises up then suddenly dips down. This is known as stalling. If the glider does this, a smooth flight pattern can be assured by adjusting the back ends of the horizontal stabilizer (elevators)

When flying your plane outdoors, if you want to make your plane curve to either direction, you can do this by bending the ailerons and rudder, as shown in the top figure (it's not necessary to make inclusions in the wings; just bend the appropriate areas slightly with your fingers to adjust the ailerons and rudder.

Alternatively, you can tilt the horizontal stabilizer. This is because the planes in this kit are designed so that they have lifting force in the horizontal stabilizer as shown in the accompanying figure. Therefore, if you tilt the horizontal stabilizer to the right, the pulling force to the right as shown causes the nose of the plane to curve left.

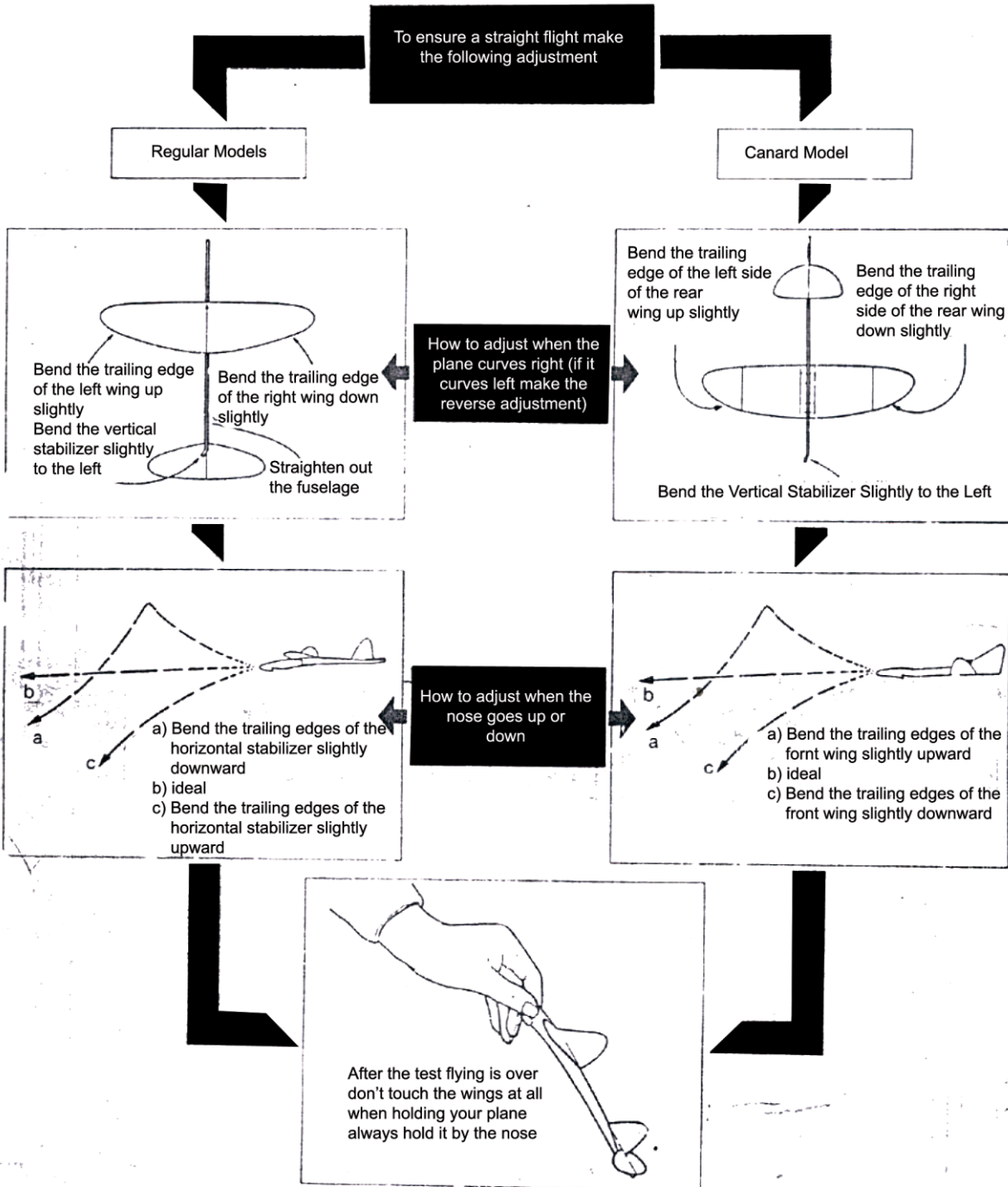
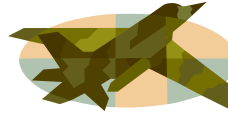

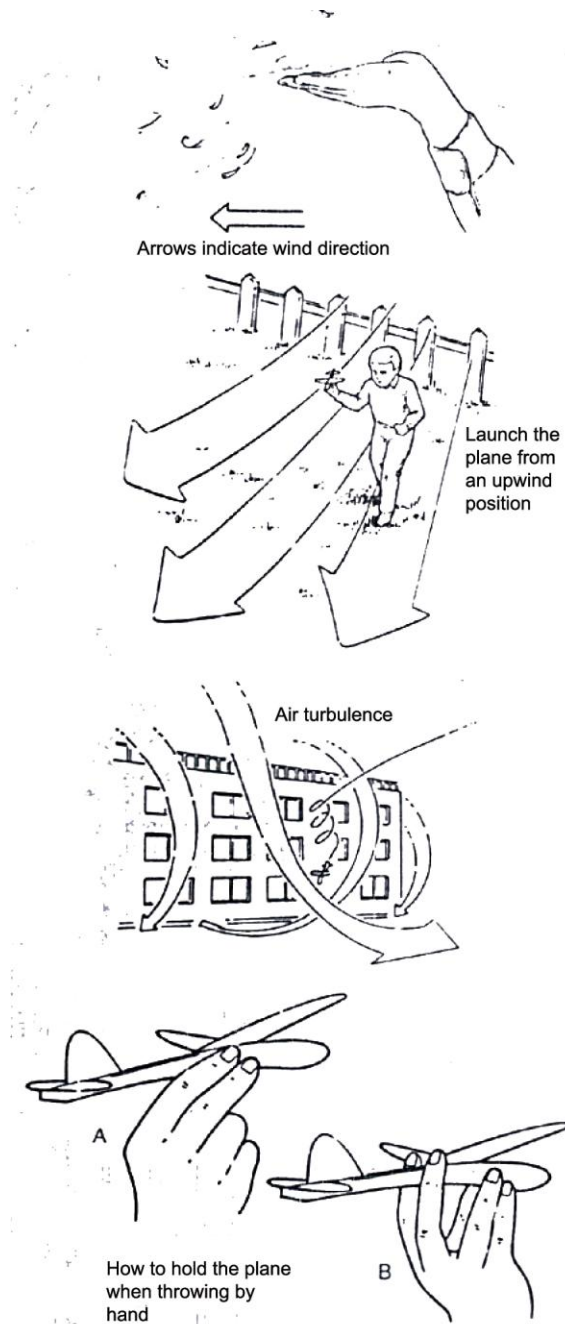
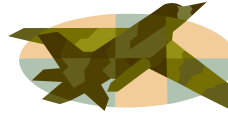

Achieving altitude

Now that the test flying is over, let's go outside to a wide open space to fly your plane!. To protect your plane from wear and tear. It's best that you fly it in a field of soft grass. When you get out into the field of soft grass. When you get out into the field, the first thing to do is to determine the wind direction. To do this, pull a few blades of grass and toss them into the air, or if a chimney is nearby, note the direction in which the smoke arises.

If you are flying your plane outside with a wind blowing and want to keep your plane's flight pattern within a limited area, it is best to throw your plane with the wind from an upwind position. Always be sure to return to the original upwind position for launching in order to prevent the plane from gliding beyond the confines of the flying area

It's not good to fly your plane if the wind is too strong. When a strong wind is blowing, great turbulence is created in the vicinity of large buildings such as apartment houses or schools. In such places you will never be able to fly your plane successfully when the wind is strong, so it's best to wait for a day when the wind is gentle.

To throw your plane high, there are two ways to hold it, as shown in the figure, either by grasping the body with your finger tips, or by placing your index and middle fingers behind the main wing, on both sides of the fuselage. Use whichever method you find easiest and most natural.

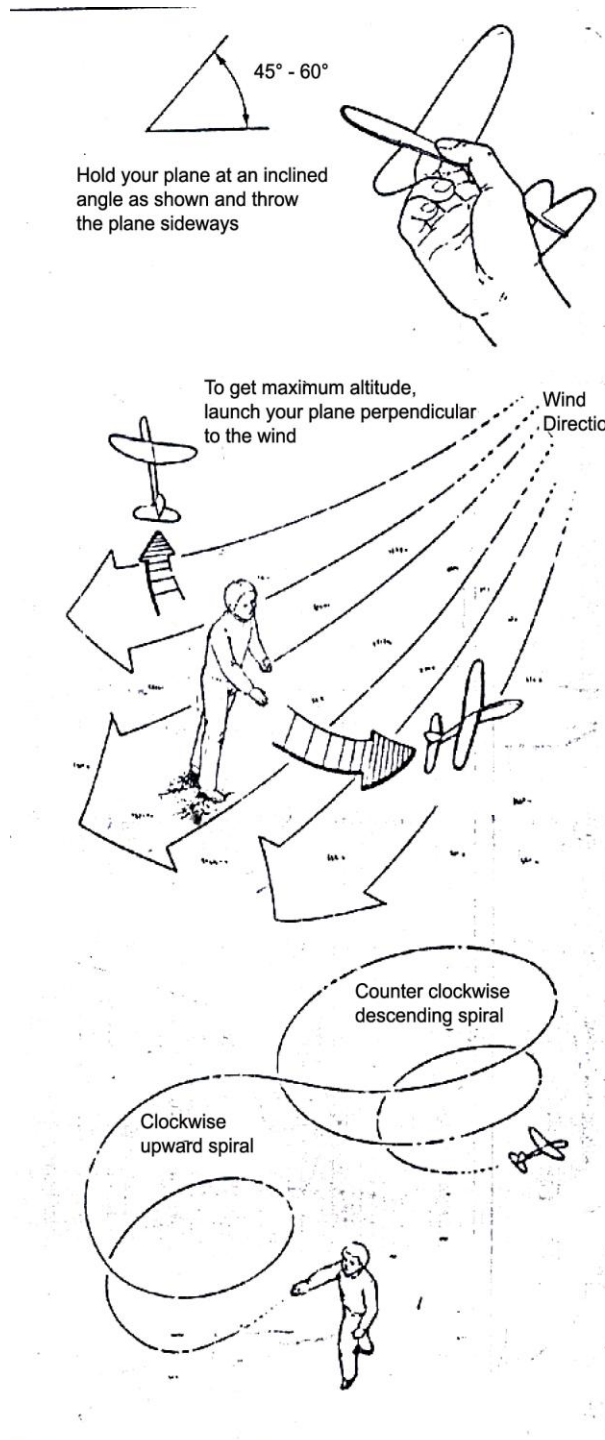
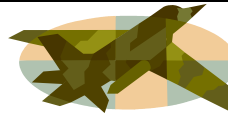

If you hold the plane horizontally, and throw it up and forward, it will loop the loop and dive down, so it is very difficult to get it to glide at a high altitude.

In order to overcome this difficulty, tilt the plane at a 45° to 60° angle to the side when throwing your plane will curve outward as it gains altitude then it will gradually level off and glide on a straight course. If your plane still tends to loop the loop, bend both rear edges of the horizontal stabilizer slightly downward to minimize this tendency.

Contrary to test flying instruction, it is great to launch your plane perpendicular to the wind when high flying it. The reason for this is that when throwing your plane upwind the plane has a tendency to loop, conversely, when throwing your plane downwind, the plane has a tendency to stall, due to the decreased relative airspeed over the wings. When throwing the plane perpendicular to the wind, none of these faults are apparent, so it is easier to obtain good flight results.

If an especially large wide open space is available, its good to fly your plane in the following manner before launching your plane adjust the main wing and vertical stabilizer in the directions necessary for a left turn. The take the plane in your right hand, incline the plane to the right and throw it upward. If you do this the plane will spiral upward in a clockwise fashion until it has obtained a considerable altitude, then it will slowly spiral to the left, in counterclockwise fashion, for its descent, if your plane has been well adjusted, it will remain aloft for at least 15 to 20 seconds.

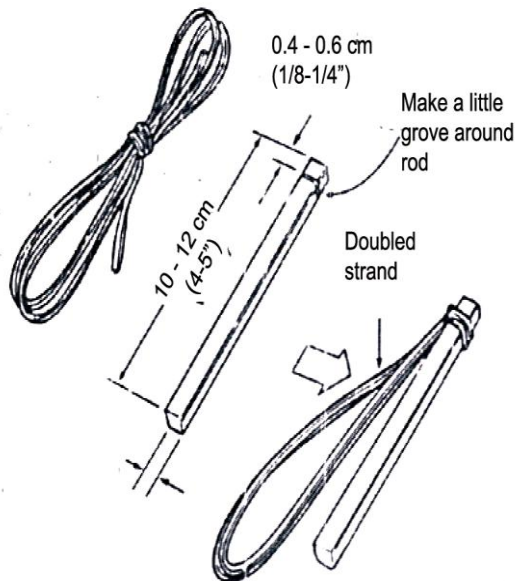
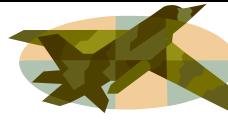

How to make a rubber band catapult

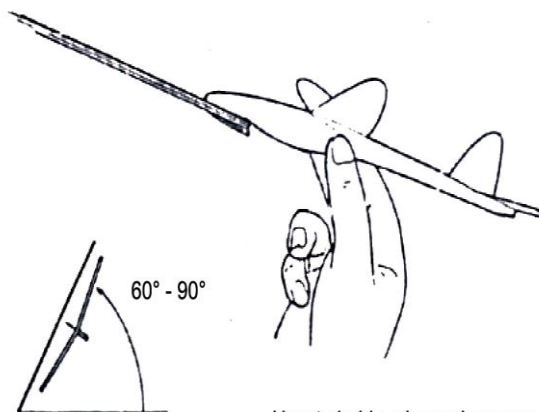

How to hold a plane when you launch it by the rubber band catapult

If you use a rubber band catapult, you will be able to fly your plane at a high altitude for a long time. Another advantage of using the catapult is its ability to maintain the desired position of the plane, as at launching and thereby ensure a proper flight course.

A catapult can be made easily from the included wooden rod and rubber band. Make a groove at the place shown in the figure and fasten the rubber band tightly onto the rod at the groove making a double strand.

When launching by catapult, suspend the rubber band on the hook, holding the fuselage securely with tip of your fingers as shown in the figure. If you use more than just your finger tips, you may sometimes damage the horizontal stabilizer when the plane is launched. Pull the plane back being careful not to bend the fuselage. You may pull back as far as you can but if you use a stronger rubber band than the one included in the kit, too much tension on the band will cause flutter. On a real plane, flutter will cause disintegration in mid-air. Flutter is occurring when your paper plane makes a vibrating sound. To avoid this problem try not to put as much tension on the rubber band.

When using a catapult, as when hand launching your plane, inclined your plane 60° to 90° from the horizontal to avoid loops. Bending the elevators downward slightly also serves to discourage loops.

* Launch your plane in a wide open area

* Since the catapult launched plane will fly at a high speed, take precautions to avoid hitting people in the area.

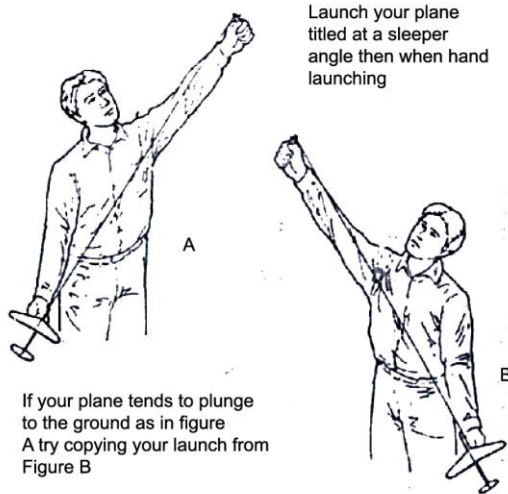
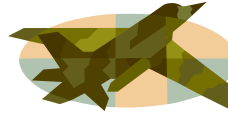

Launch your plane titled at a sleeper angle then when hand launching

If your plane tends to plunge to the ground as in figure A try copying your launch from Figure B

Launching by the catapult

When considering the proper inclination that your plane should have when catapulting it, you must remember if you have a plane that tends to curve to the right, the more you incline it with the right wing downward (as in Figure A) the more the plane will tend to plunge down to the ground, if you try reversing this inclination and ground incline the left wing downward (as in Figure B) you will obtain better flight results.

All the models in this Heritage Series, except for the Voyager, Can be launched by a double strand rubber band catapult. Flutter will not be a problem if all parts are securely glued. Only the problem if all parts are securely glued. Only the Voyager should be gently launched by a single strand rubber band catapult.

When you want your plane to spiral upwards in the way mentioned on page 15, by hand or catapult, launch it titled away from you at a 70° - 80°+ upward angle.

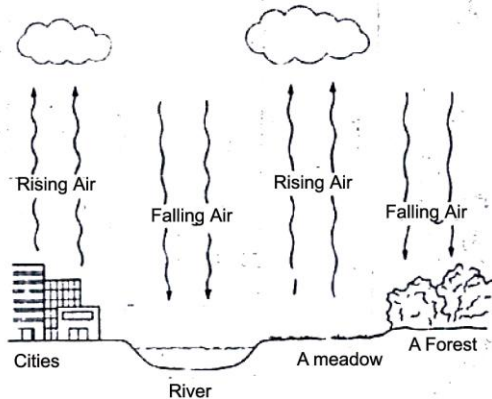

How to catch rising air currents

In order for a paper plane to stay aloft for over 30 seconds, it must make use of rising air currents. Rising air currents can be of two kinds those resulting from the flow of wind over an inclined surface, and thermals which are rising columns of warm air.

Paper planes fly well in thermals "Thermals" Originate when the earth's surface is heated by the sun. They usually originate over city streets, deserts, and plains with short grass, lakes, rivers, and forests, however, are difficult to heat up, so these areas favor the formation of down drafts, or descending air currents, you will be most able to make use of these "Thermals" if you fly your plane over wide open grassy areas or concrete lots.

To enable your plane to make best use of these thermals, it's best to adjust it to fly in a circular pattern, then launch or throw it as high as you possibly can. Although invisible to the naked eye, there are what can be called "bubbles" of rising air, like that shown in the accompanying figure, over patches of heated ground. Therefore if you throw your plane as stated above and get it to go around in circles and the plane enters one of these "bubbles" its chances for remaining inside this "bubble" for a considerable length of time are increased.

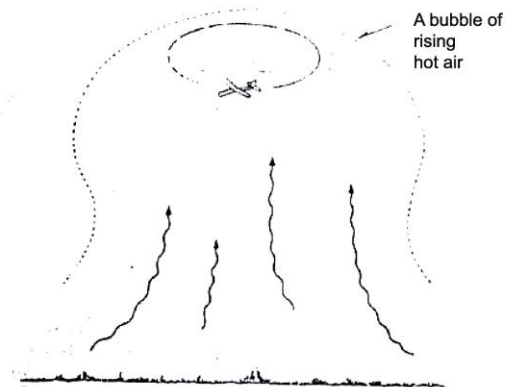
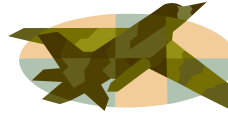

9 AM - noon is the best time
to make use of thermals

Winds get strong in the
afternoon

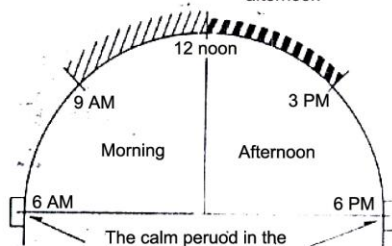

The calm period in the
morning and the evening
are the best for
test flying

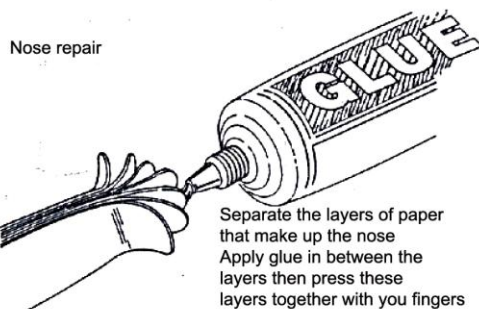

Nose repair

Separate the layers of paper
that make up the nose
Apply glue in between the
layers then press these
layers together with your fingers

All the racer models included in the kit are designed to fly over one minute in rising air currents if adjusted carefully.

The best time to make use of thermals is between 9 AM and 12 noon on days when the skies are clear and the winds are gentle. Although the strength of thermals increases during midday (9am – 4pm) when the sun is shining most strongly and the highest temperatures are reached in the afternoon, when thermals are strongest, gusty surface winds also get stronger, often making it difficult to fly paper planes.

Actual atmospheric conditions will not always occur at the above mentioned times however, so always keep an eye out for chances to fly your plane.

Repairs

Even if your plane becomes damaged, if you repair it you should be able to fly it again and again.

When paper planes dive to the ground or crash into a wall, the nose is especially vulnerable to damage. If any dirt or pebbles imbedded in the nose, remove them with a pair of tweezers or a knife. Separate the various layers of paper as shown in the figure and coat all the inner surfaces with glue. Then press the layers together from the outside and pressing hard, squeeze out all the excess glue, just as you did during assembly. Let the glue dry thoroughly if the wings are fuselage are bent or torn, reinforce the damaged parts from the outside by gluing on small pieces of paper, as shown in the figure.

These small pieces of paper should preferably be pieces of scrap paper left over from building your plane. These pieces of paper are bend resistant in the direction of the wing tips so be sure to cut out and apply them in the proper direction. (Bend resistant direction of the paper is indicated by an arrow in the lower right hand corner of each model sheet)

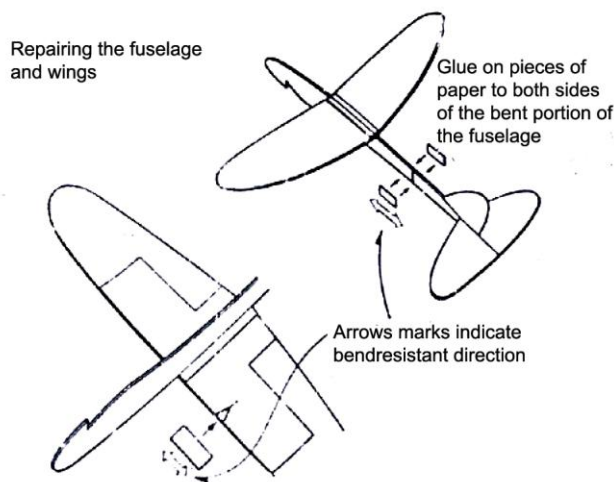
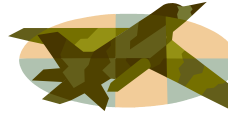

To patch a torn wing apply a small piece of paper

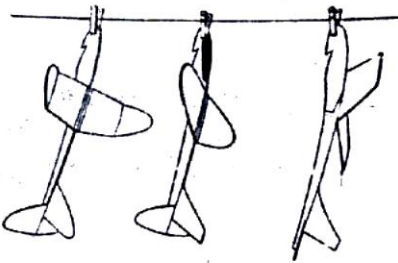

Stretch a wire across an open space and hang your planes on it with clothespins

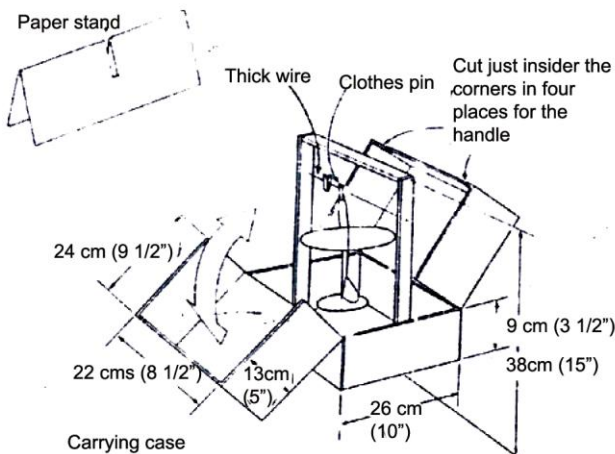

Storage

If your paper planes are well made, you should be able to preserve them with minimum care, thus enabling you to fly them for many years. For storing a large number of plains when not in use, you should stretch a piece of wire between two hooks and fasten the planes by their noses with clothespins. Let them hang vertically as shown in the figure. This has the advantage of taking up only a small amount of space, and also of minimizing the accumulation of dust on the wings.

Enjoy displaying your airplanes

You can enjoy airplanes not only by flying them, but also, for example, by viewing them on a stand on your desk. The sleek lines of the plane's body will set your imagination off. A paper stand, that can be made very easily, is quite useful as a support for displaying an airplane.

1. Prepare 4cm Square piece of paper.
2. Fold it in half.
3. Make an incision with a width of approximately 1.5 – 2 mm (1/16") at the center of the piece of paper.
4. Inset the fuselage between the cut.

Transporting your plane safely

In order to transport your paper planes safely from your home to an open area, I recommend using a carrying case. You may make it yourself from a carton or a light wooden box.

The carrying case should be large enough to accommodate each plane in its own space without overlapping with the others and so the planes are ready to fly with only a little adjustment. Here is one example of a carrying case I have made.

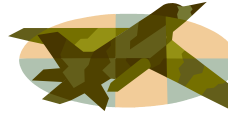

3. Introduction to Paper Plane Design

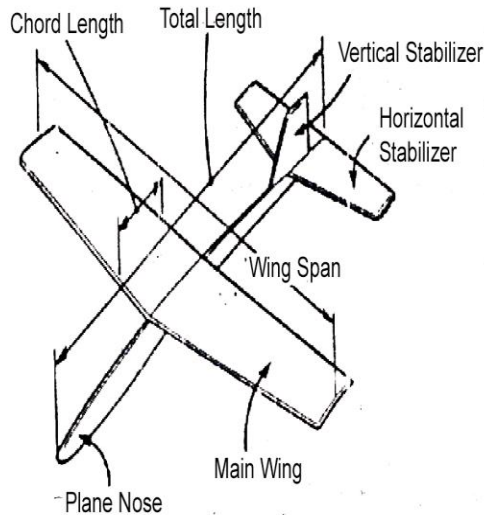

Fig.1 Plane parts and special terms

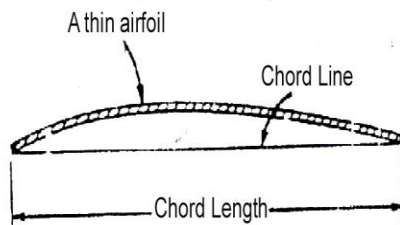

Fig.2 Cross Section of a thin airfoil

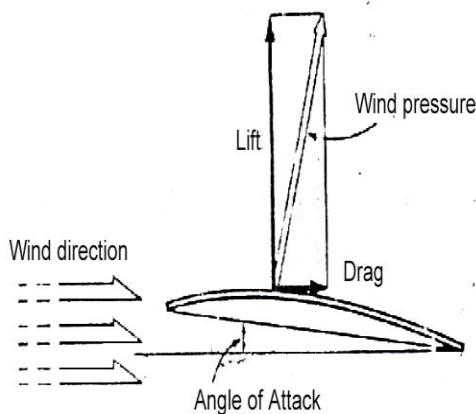

Fig.3 Angle of attack and forces on wing

How to make your plane fly well

To make a paper plane fly its best, two conditions are very important

- 1) Since a paper plane is a glider it must have good gliding performance. This will be explained more later, but basically, this means that the glide ratios is high and the rate of descent is low.
- 2) The plane must have good stability. This means that it must be able to correct itself and maintain a good flight after tilting or turning

If your plane has these two qualities, when you throw it high into the air it will glide smoothly for a long distance even when there is slight air turbulence.

How to improve flying performance

Figure 1 shows an airplane's parts and what they are called.

The most important part of a glider is the main wing. Its job is to support the plane in mid air. The Shape of a wing's cross section is called a wing section or airfoil. The chord line shown in the figure is the base line of the airfoil. Its length is called the chord length.

In figure 3, we can see that the angle made by the chord line wind direction is called the angle of attack, when the fuselage is designed, a base line is drawn across the body to assist in drawing and construction. The angle formed by this base line and the chord line is called the angle of setting. The angle of setting does not change on a plane's body, but the angle of attack changes a the plane's vertical direction changes (fig .4)

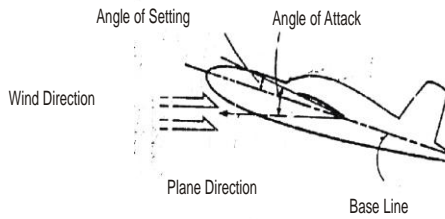
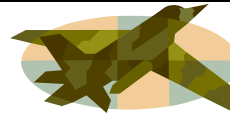

Fig 4. Angle of Attack and Angle of Setting

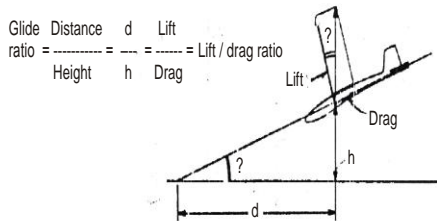

Fig 5: Glide ratio and lift / drag ratio have the same value

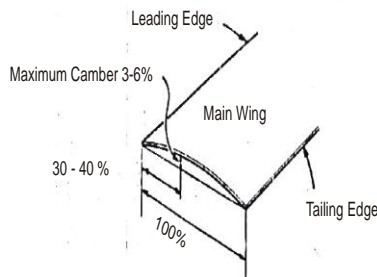

Fig 6. A thin air foil is easy to make and suitable for paper planes

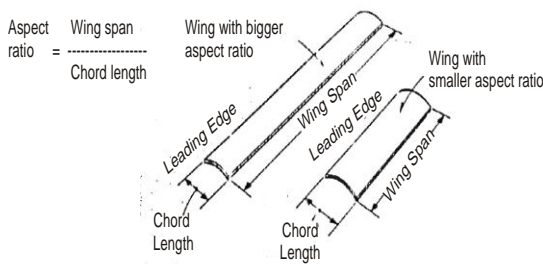

Fig 7 : Aspect Ratio

When the plane is gliding, wind pressure creates two forces on the wing as shown in figure 3. One force is the upward draft of air (Called lift) and the other force on the wing is called air resistance or drag. The ratio of these forces is called the lift / drag ratio. The higher the ratio of the wing (Strong lift and little drag) the better the plane will fly.

As shown in figure 5, the ratio between the distance a plane will glide and its altitude is called the glide ratio. A plane with a high glide ratio will fly farther than a plane with a lower glide ratio. The glide ratio has the same value as the lift / drag ratio of the entire plane so for long flights the lift / drag ratio must be as high as possible.

In order to have high lift / drag ratio you must choose a good wing shape. A wing that is easy to make with a high lift / drag ratio is shown in figure 6. As described in the Chapter "Assembly Instructions. This thin type of wing is easily made by cambering the wing carefully with your fingers.

It is very important to decrease the air drag by slimming the fuselage or by omitting parts which jut out such as the landing gear, struts etc as much as possible. A special ratio used to decrease drag on the wing is called the aspect ratio.

The aspect ratio is found by dividing the wing span by the chord length. The greater the aspect ratio the more slender the wing will be. As the aspect ratio of the main wing becomes larger, the less the drag on it. Real gliders and planes designed for long distance flights have long slender wings for less drag and greater lift. On a paper plane, however, which has a small body and flies at low speeds, there is no need to make the wing too slender. Rather it is best to build a light and sturdy main wing with an aspect ratio of about 5 or 6.

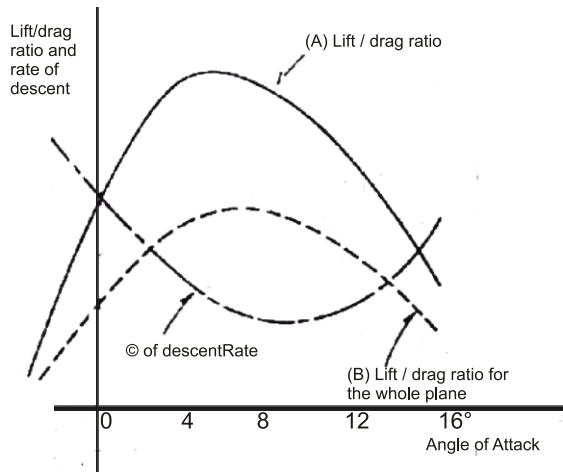
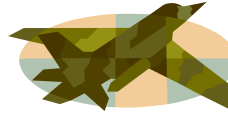

Fig 8. Lift / drag ratio and rate of descent depending on angle of attack

The lift / drag ratio changes with the gliders angle of attack. Figure 8 shows the changes. Line (A) shows the lift / drag ratio for the main wing. A 3° or 4° angle of attack is most desirable. Line (B) shows the lift / drag ratio of the whole glider. Since there is more drag on the entire glider, a 5° or 6° angle of attack is best.

When a plane is gliding and slowly, losing altitude, this is called the rate of descent. It is measured in meters per second. For a long duration, flight you must decrease the rate of descent. In figure 8, line (C) shows the rate of descent. When the angle of attack is a little larger, (i.e. 1° to 2° greater than that for the best lift / drag ratio), the rate of descent is the smallest.

The weight of the whole plane, divided by the surface area of the main wing, is called the wing loading. A heavy plane with small wings, will have a large wing load. The lock heed F-104 is an example of this principle. Planes with high wing loads glide faster and so their rate of descent is high.

On an actual light plane or glider the surface area of the main wing is relatively large, and because the plane is light, the wing loading is small. Due to these factors, the rate of descent is low. Accordingly they can glide, cruising for long periods of time.

When designing paper planes for long duration flights, it is best to have a low wing load by making a large wing area with a body as light as possible so your plane will fly for a long time.

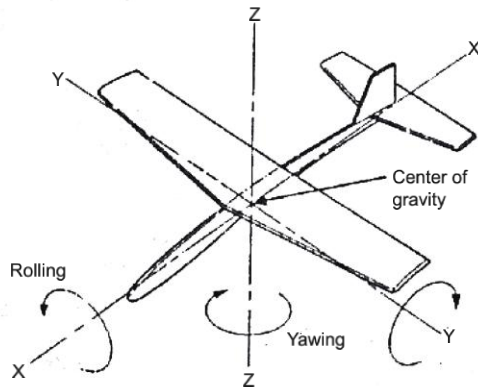
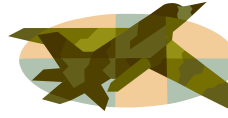

Fig 9 Inflight motion

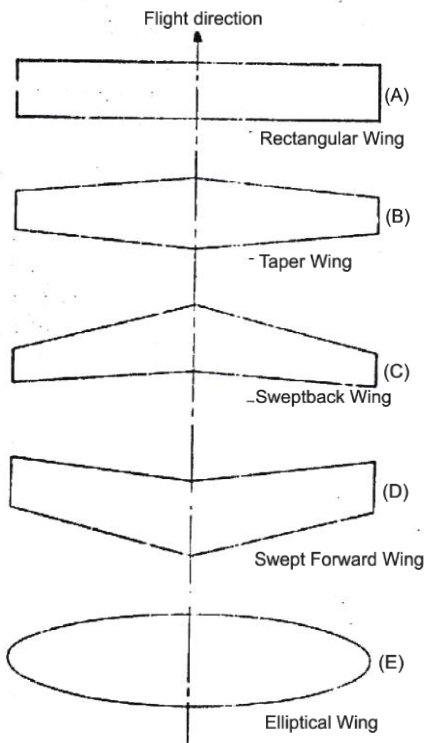

Fig 10 Wing Shapes

How to improve stability

For a plane to fly well, it must be stable. Figure 9 shows the movements of a plane in flight. The parts which control stability are

HORIZONTAL STABILIZER

- Controls Pitching

VERTICAL STABILIZER

- Controls Yawing

DIHEDRAL ANGLE ON MAIN WING

- Controls rolling

For a stable plane all of these must be designed and attached properly as described in the next chapter.

Elementary design method

1. Designing the main wing

The plane's gliding speed and rate of descent depends a lot upon the wing loading. You must decide on the wing area that is best for the plane you are building/

When you design a plane for a long, slow buoyant flight give it a large wing area.

When you design a high speed sleek jet plane, make the wing area small.

However, be careful not to make the wing loading too small, Although it will decrease the rate of descent, the plane won't go up very high when thrown into the air, resulting in short flight. A wing span of less than 30 cm (12") is recommended considering the strength of the paper.

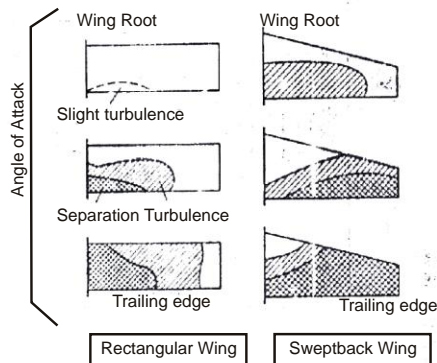
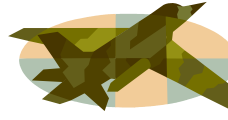

Fig 11 Occurance of stalling differs for planes with rectangular wings and those with sweptback wings.

(From Report and Memorandum No.1976 of the Royal Aircraft Establishment)

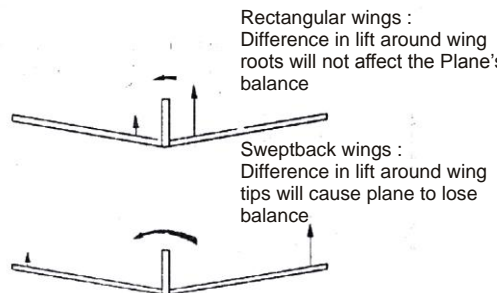

Fig 12 Difference in Stall on Rectangular Wings and Sweptback Wings

2. Main wing surface shape

You can choose the wing shape you like best from the shapes in Figure 10. If the wing is either too narrow (high aspect ratio) or too wide (low aspect ratio) the plane will not be stable nor fly well. For a good flying air plane, try to avoid odd shaped wings.

The sweptback wing tends to cause "tip stall" which sends the plane into a spin, so it is best to avoid a wing with a large sweptback angle

Figure 11 shows the relationship between the angle of attack and stalling on the rectangular wing and the sweptback wing. On the rectangular wing, air turbulence affects the central part of the wing, while on the sweptback wing turbulence affects the wing tip which sends the plane into "tip stall" when tip stalling, the plane suddenly loses its lift.

Differences in the effect of air turbulence and bends or warps in the wings cause differences in wing lift. This will result in stalling (fig 12). The sweptback wing plane will go into a spin when it stalls. And so although the sweptback wing looks quite good its design does present some problems.

3. Center of gravity and wing angle of setting

The angle of attack must be determined according to the type of glider you choose, whether it is for a long duration flight on a long distance flight, The placement of the Center of gravity and the angle of setting for the main wing and horizontal stabilizer for these two types of gliders are shown in Figures 13 and Figure 14. When the wings are positioned in this way, the angle of attack of the plane will be near to that previously explained (See Fig 8)

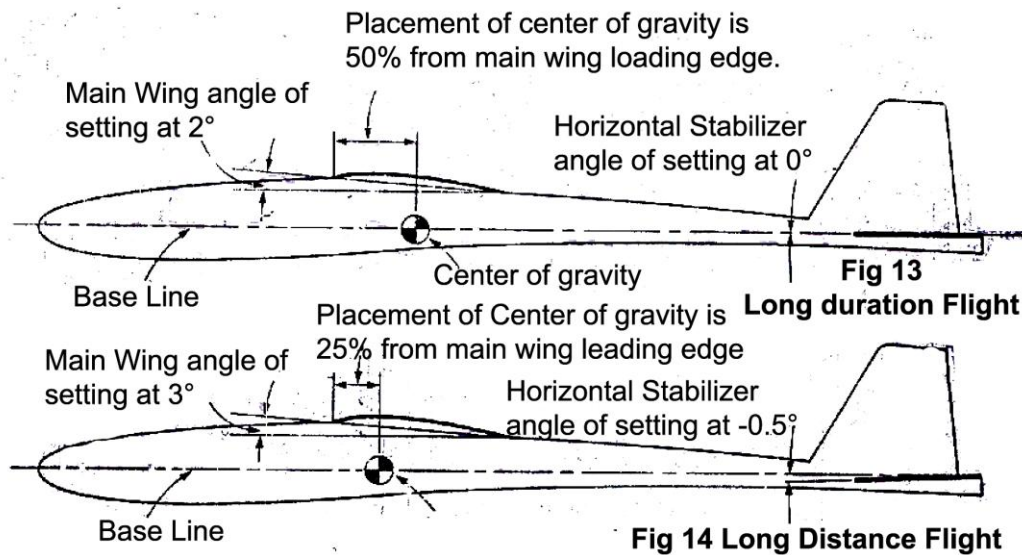
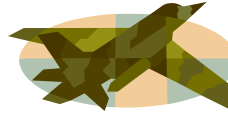

A plane which has the center of gravity further back will be especially well balanced against pitching both at high speeds when launched and during slow gliding. Therefore the plane design having the center of gravity set back is suitable for a wide speed range.

When the wings and the center of gravity are placed according to the guidelines, then the fuselage can be designed according to what glider type you choose. The horizontal stabilizer setting might have to be adjusted to get good balance but this can be done after the test flight.

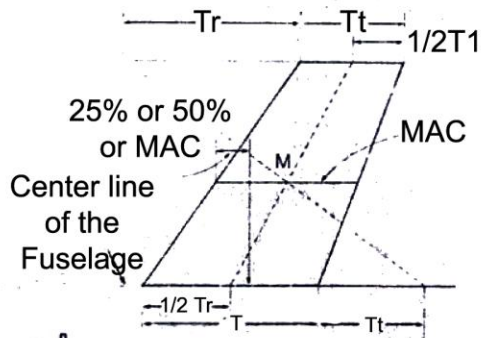
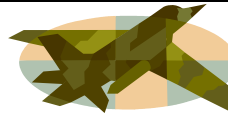

Fig 15 How to find Mean Aerodynamic Chord Mac

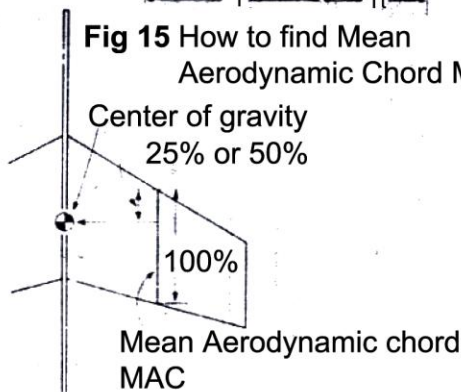

Fig 16 : Center of gravity is decided using MAC formula for any wing shape not rectangular

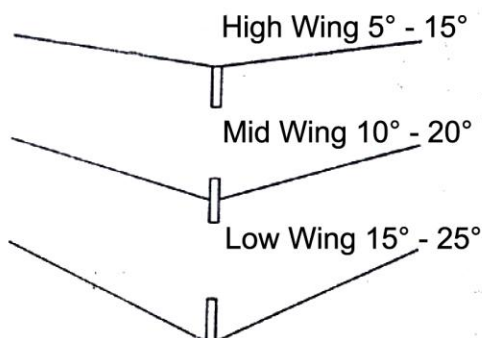

Fig 17 : Wing position and suitable dihedral angle

4. Center of Gravity on Non-rectangular wing planes

In figures 13 and 14, the center of gravity of the airplane is placed at a point 25% or 50% of the chord length from the main wing's leading edge for the rectangular wing (Fig 10-A) the chord length is the same for every part of the wing so it is easy to find the center of gravity. In the other wing shapes, the chord length changes at different places on the wing. The center of gravity on these wings depends upon the average chord length which represents the aerodynamic characteristics of the wing. The chord length is called the Mean Aerodynamic Chord (MAC) and it is easy to find. The shaded parts in Figure 15 are half the main wing (From Center to Wing tip).

Make a sketch of the wing in which Tt is the Chord length at the wing tip and Tr is the Chord length at the wing root. Extend line Tt the distance of line Tr and extend line Tr the distance of line Tt. Connect the two points (T & R) at the end with a dotted line. Find 1/2 Tr and 1/2 Tt and divide the wing with another dotted line. These two lines from Point M. this line will be the Mean Aerodynamic chord length of the wing. The Center of gravity should be placed at a point 25% or 50% of the MAC as seen in Figure 16.

5. The Dihedral Angle

The reason a plane can recover from temporarily rolling to either side while in flight is because of the dihedral angle placed on the main wing.

As shown in Figure 17 the dihedral angle should be 5° - 15° on a high wing glider and 15° - 25° on slow wing glider

The sweptback wing of the jet plane serves the same function as a dihedral angle. On jet planes with sweptback wings, a smaller dihedral angle than the values listed in Figure 17 is used.

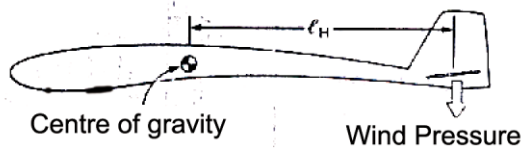
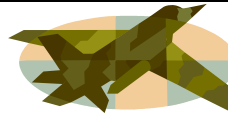

Fig.18 : Stabilizer works as a lever with center of gravity as a fulcrum

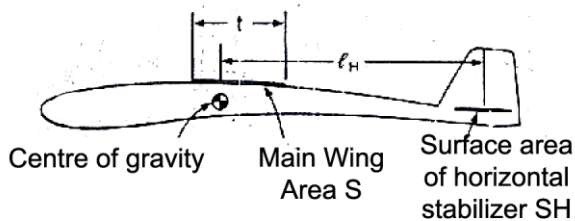

Fig 19 : How to find surface area of the horizontal Stabilizer

6. The horizontal Stabilizer

The horizontal and vertical stabilizers act independently as levers supporting the center of gravity. The distance (l) between the center of gravity and the horizontal and vertical stabilizers is very important. By multiplying the size of the stabilizers by this distance (l) we can find how well the stabilizers work. The product is called the tail volume.

To find the best surface area for the horizontal stabilizer (S_H) the following formula is used.

Long duration flight

$$S_H = 1.2 \frac{S \times t}{l_H}$$

Long distance flight

$$S_H = 0.6 \frac{S \times t}{l_H}$$

S = Main wing surface area (cm²)

T = Chord length (cm)
or MAC for any wing shape not rectangular

l_H = Distance from center of gravity to horizontal stabilizer (cm)

The surface area of S_H as determined by the above formula is bigger in Figure 13 than the Figure 14. This is because the further back the center of gravity the more unstable the plane will be. Therefore, a large surface area on the horizontal stabilizer is necessary.

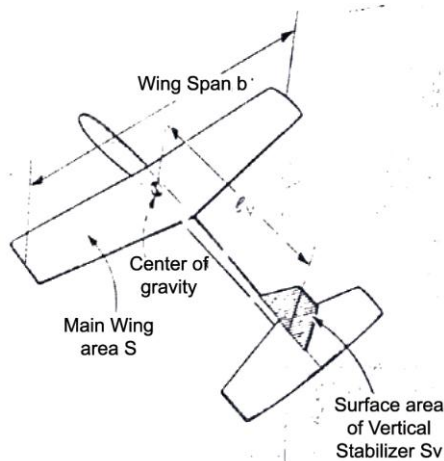
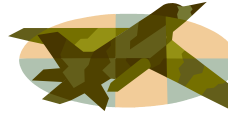

Fig 20 How to find surface area of the vertical stabilizer

7. The vertical Stabilizer

$$S_v = 0.05 \frac{S \times b}{l_v}$$

S = Main wing surface area (cm²)

b = Main wing span (cm)

l_v = Distance from center of gravity to vertical stabilizer (cm)

The surface area of the vertical stabilizer is found using the above formula. This figure is only an estimate of the stabilizer's size. For a more precise figure the surface area of the plane body and main wing dihedral angle must also be taken into consideration.

If the vertical stabilizer is too big, or too small, the glider will not fly well. If the stabilizer is too large, the glider will tend to go into a spiral descent. If it is too small the plane will tend to spin. To find the best size for the vertical stabilizer, make it slightly larger than the size you figured in the above formula. During test flights trim it until the back end begins to sway slightly from side to side. It's fun to practice this method, so give it a try!

As long as the size of the horizontal and vertical stabilizers is right, then you may choose whatever shape you like.

8. Test Design

Let's design a paper plane now using the aforementioned explanations. We will design a rectangular winged plane for long duration flying. If we make the main wing span 22cm and the chord length 4cm, then the main wing surface area calculation is

$$S = 22 \times 4 = 88 \text{ cm}^2$$

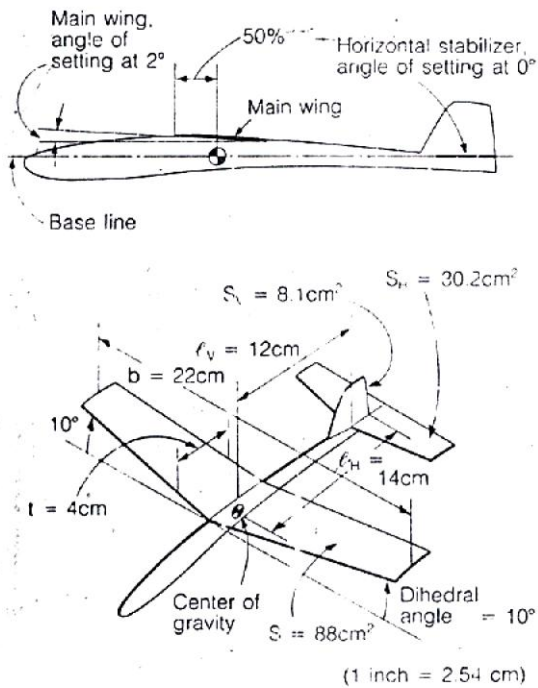
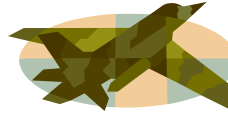

Fig.21 Test design for long duration flight

Layering the nose increases strength.

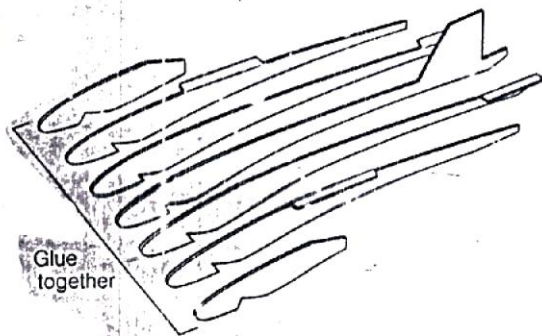

Fig.22 Composition of the fuselage

If we put the center of gravity 50% back from the main wing's leading edge (See Fig 13) and make the distance from the center of gravity to the horizontal and vertical stabilizers respectively $l_H = 14\text{cm}$ and $l_V = 12\text{ cm}$, we can calculate S_H and S_V using the following equations (see fig 19 and Fig 20)

$$S_H = 1.2 \frac{88 \times 4}{14} = 30.2 \text{ cm}^2$$

$$S_V = 1.2 \frac{88 \times 22}{14} = 8.1 \text{ cm}^2$$

When deciding the distance from the center of gravity to nose tip. Choose a length similar to that of one of the Paper Wings models. If the distance is either too long or too short, the plane will fly poorly. You can, however, design the shape as you like.

From the above values your design will be similar to the glider in figure 21. I have made a test model of this plane and I found that it flies very well enjoy designing one for yourself.

9. Plane Body Construction

When throwing the glider by hand or by catapult, the wings must be able to withstand extreme wind pressure. Also the plane must be sturdy so it will not bend or rip when it hits the ground or walls

For a top quality glider, some parts are designed for strength while others need to be as light as possible the shape of the glider should be designed with the following conditions in mind. It must be easy to launch by hand, simple to repair when damaged and it must have little wind resistance.

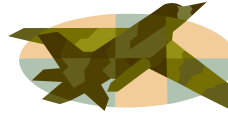

The weakest areas are just in front of the main wing and horizontal stabilizer

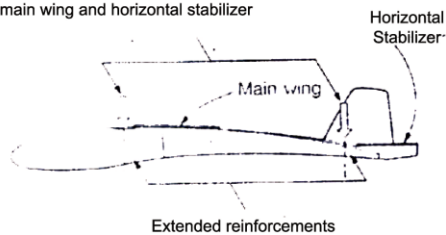

Fig 23 Reinforcement of easily bendable parts

To meet these requirements the actual construction of the plane body, as shown in Figure 22, is made up of layers of heavy paper. There are more layers in the nose for added strength in Figure 23, the dashed lines show where the glider tends to bend easily. To prevent this parts (A) and (B) extend past the arrow marks for reinforcement.

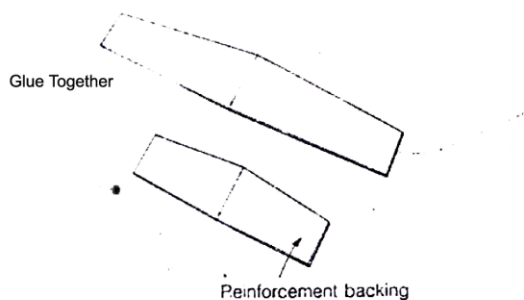

Fig.24 Composition of the main wing

As shown in figure 24, a backing is glued to the underside of the wing's center in order to keep the main wing from bending and twisting due to wind pressure, Further, to obtain better performance, the wing should be slightly cambered as in Figure 6. This type of main wing is also easy to repair.

10. Layers of Paper and Bending Strength

One of the main reasons why paper planes don't fly well is that the midsection, the part of the body between the main wing and the tail tends to bend from side to side. When this happens the plane spirals down sharply after it is launched it is thus important to try to design you planes so that they don't bend in this section.

It is for this reason that Paper Wings paper air planes are designed to be 5 to 7 layers thick in the midsection of the fuselage, As you can see in Figure 25, the bending strength is proportionate to the cube of the width (w) times the height (m)

Bending Strength $\propto (w^3 \times m)$

Taking the thickness, and thus the strength of one piece of paper as a constant, we can substitute the number of layers of paper (n) for the width (w) as follows :

Bending strength $\propto (n^3 \times m)$

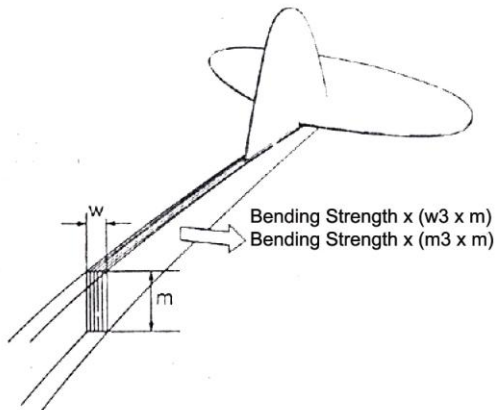
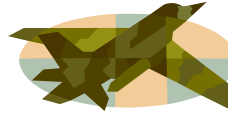

Fig 25 : Dimensions of the fuselage and bending strength

If we compare the use of six layers of paper with five layers of paper, we find that six layers of paper lead to about 1.73 times the strength

$$\frac{6 \text{ layers} \quad 6^3 \times m \quad 216}{5 \text{ layers} \quad 5^3 \times m \quad 165} = \frac{216}{165} = 1.73$$

One other thing that becomes clear is that it is much more effective to increase the number of layers of paper than it is to increase the height of the body in order to increase strength and reduce bending. If too many layers of paper are used, however, the plane becomes too heavy. At the same time, it is important to make sure that the several layers of paper are glued together securely. If the gluing is incomplete, then the bending strength is $n \times m$ rather than $n^3 \times m$ leading to a much reduced strength.

The racer type planes included in this Paper Wings kit consist of both 5 to 7 layer designs. When you fly them you will feel a slight difference between the two. While you'll need to be much more careful about how you fly the five layer ones, you'll see that they have a lighter and spirited feeling to their flight. I hope that you'll try constructing flying, and comparing the performance of both types to see for yourself how different they are.

This concluded my explanation of simple design methods. You can now use this knowledge to help you design your own gliders.

Good Luck and Good Flying!

4. How to build Paper Wings

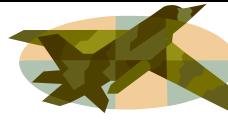

How to assemble the most wings:

Three of the racer type planes in this Heritage Series have a high performance main wing featuring a uniform camber along the length of the wing. Because the shape of the central part of the wing resembles a so-called saddle shaped surface in math, I call this type of wing a MOST (Modified Saddle Type) wing. It is constructed as follows.

CAUTION 1

The parts numbers used below are for the Racer 521. As the part numbers and dihedral angle may change according to the model, be careful when you use these instructions for other models.

CAUTION 2

When constructing the Racer 522, start with step 0.

■ Glue parts together in the order indicated.

1. Glue parts ⑩ and ⑪ to the undersides of parts ⑧ and ⑨ respectively. When dry, cut off the protruding portions.

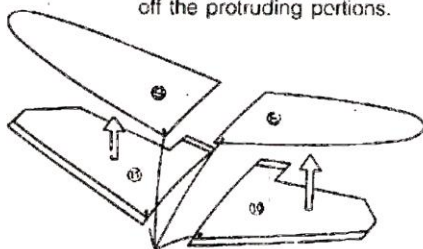

Dots toward the front.

2. Using a ruler along the center line, fold part ⑫ from the center line to make a 15° angle on both sides. Then curve it carefully with your fingers to fit the curved edge of the fuselage top where the main wings are to be attached.

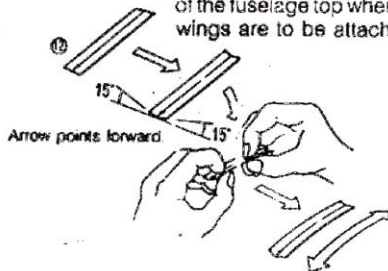

Arrow points forward.

3. Curve the main wings, ⑧ + ⑩ and ⑨ + ⑪ respectively, in the manner shown in the figure on page 9. This curve is called camber.

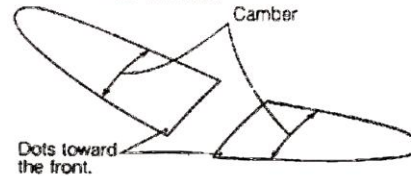

4. Apply glue on half of the underside of ⑫ and glue onto ⑧ + ⑩ (The arrow should point toward the dot.)

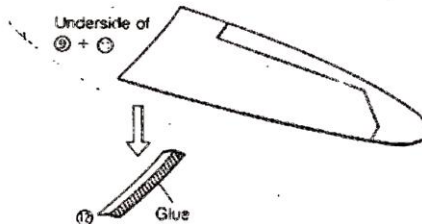

5.

In the same manner as in 4 attach ⑧ + ⑩ to the other side of ⑫

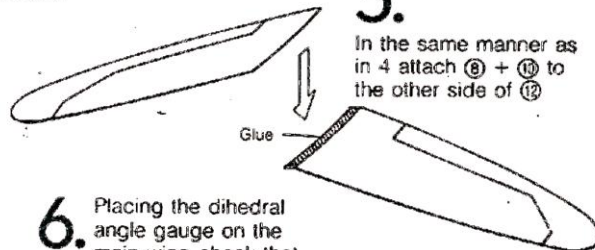

6. Placing the dihedral angle gauge on the main wing check that the dihedral angle is 15°.

7. Putting folded stands under the main wing will be conducive to fast and thorough drying.

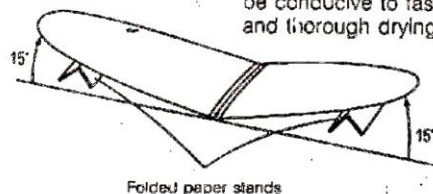

0.

Dots toward the front.

Cut parts ⑧ and ⑩ along the solid lines up to the dashed lines. Then placing a ruler along the dashed line, bend the resulting strips slightly upward.

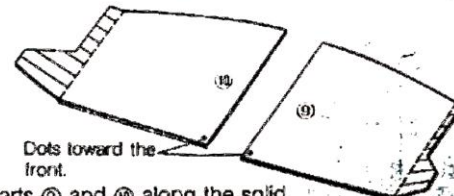

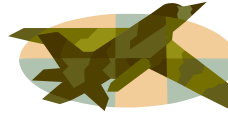

Racer 520 AMELIA

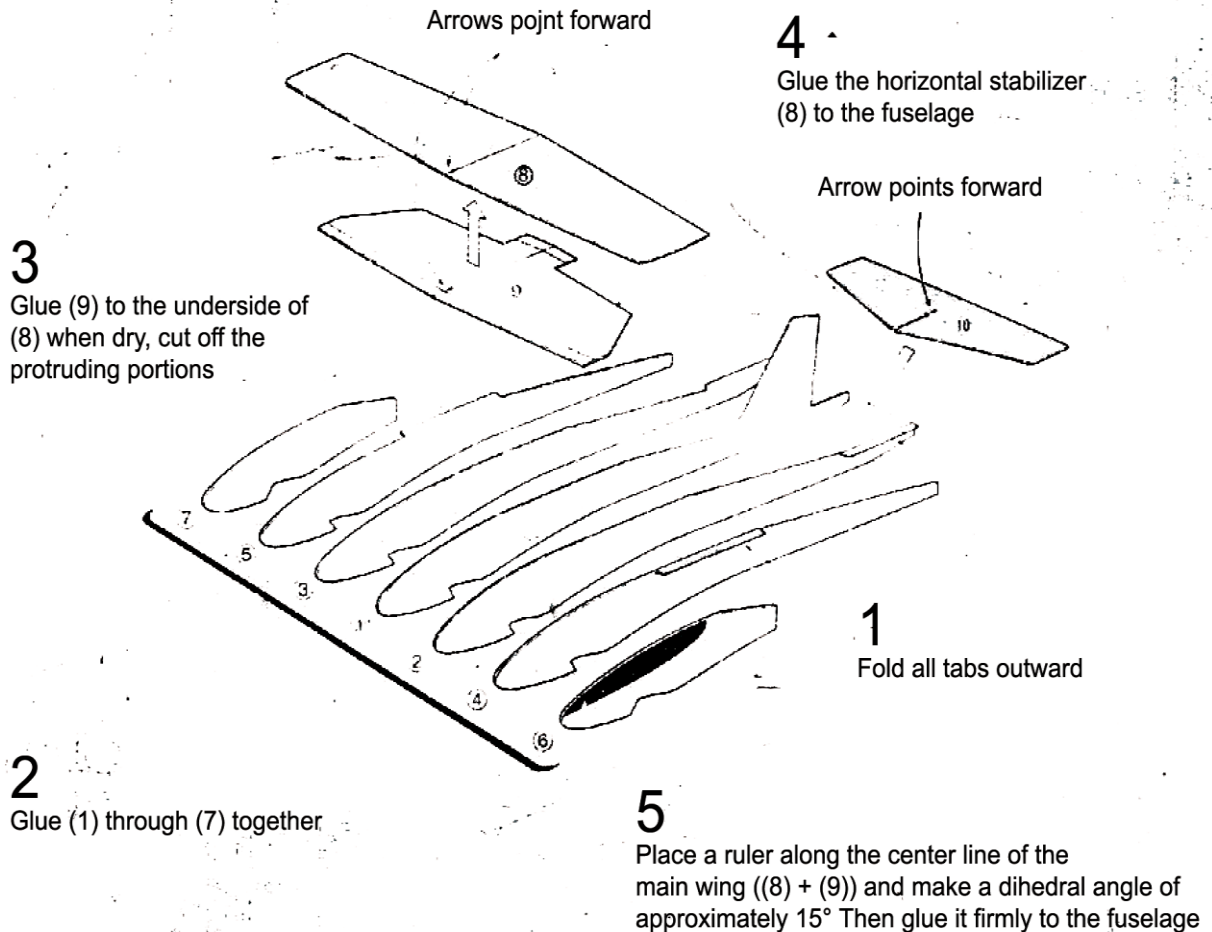

Finishing Touches

Give the finishing touches to the plane after it dries thoroughly.

6. Chamber the main wings carefully with your fingers.
7. Using the dihedral angle gauge make sure the dihedral angle for the main wing is 15°
8. Fold (11) up slightly along the center line and glue it onto the center of the main wing.
9. View the plane from both the front and the back and straighten any warps or bends in the fuselage and the wings.

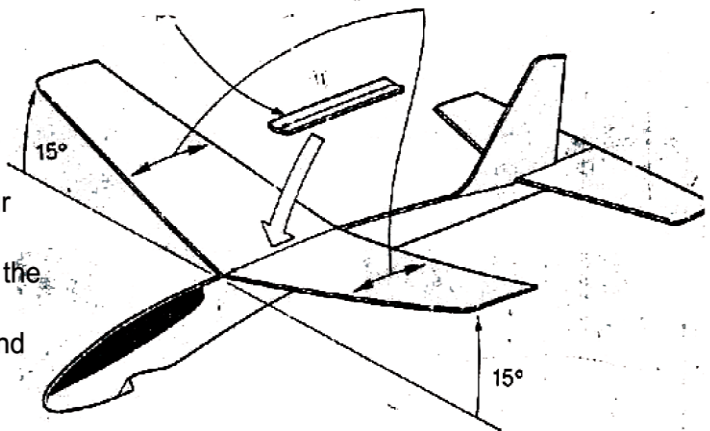

TEST FLIGHT:

Test fly the plane according to the test flight instructions on pages 8 to 10.

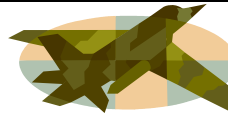

Racer 521 JACQUELINE

Jacqueline Cochran (1910–1980)
Soon after her first flying lessons in 1932, Jacqueline mastered the technical aspects of aviation and navigation. She was the first woman to enter the Bendix Transcontinental Air Race in 1935, and captured the Bendix Trophy in 1938.

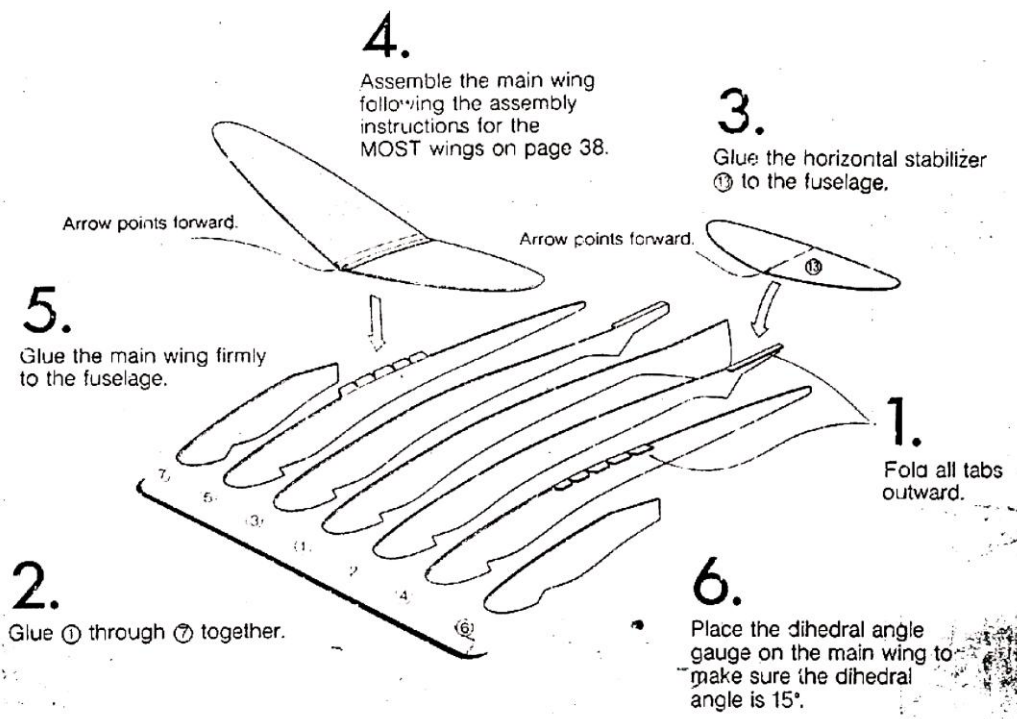

- FINISHING TOUCHES**
- Give the finishing touches to the plane after it dries thoroughly.
 - 7. Camber the main wings carefully with your fingers.
 - 8. View the plane from both the front and the back and straighten any warps or bends in the fuselage and wings.
- TEST FLIGHT**
- Test fly the plane according to the Test Flight instructions in pages 8 to 10.

