

# REGULAR CLASS REQUIREMENTS

**The Regular Class will be divided into 3 phases**

Phase 1: Design Report

Phase 2: Technical Presentation

Phase 3: Flight Round and Technical Inspection

## **Aircraft Requirements**

1. No Lighter-Than-Air or Rotary Wing Aircraft. Competing designs are limited to fixed wing aircraft with wheels only.
2. Fully configured for takeoff, the free standing aircraft shall have a maximum combined length, width, and height (L+W+H) of 170 inches.
3. Regular Class aircraft (RCA) may not weigh more than five kilo gram (5 kg) and not less than two kilo gram (2 kg).
4. The use of Fibre-Reinforced Plastic (FRP) is prohibited on all parts of the aircraft. The only exception is the use of a commercially available motor mount and propeller. Exploration of other materials and building methods are greatly encouraged.
5. Regular class aircraft are restricted to electric motor propulsion only.
6. Gearboxes, belt drive systems, and propeller shaft extensions are allowed as long as a one-to-one propeller to motor RPM is maintained.
7. Regular Class aircraft must be powered by a commercially available Lithium-Polymer battery pack. Required: 4cell (14.8 Volt) - 6 cell (22.2 volt) Lithium Polymer (Li-Po) battery pack.
8. Payload Bay Dimensions :

A “Closed” payload bay is defined as having four sides, a bottom and a top. The top can be a hatch or the wing once installed on the aircraft. The payload bay must be fully enclosed within the fuselage and the aircraft must be structurally airworthy with and without the payload installed

Length	Width	Height	Tolerance
10.00"	4.00"	4.00"	+ 0.125", - 0.000"

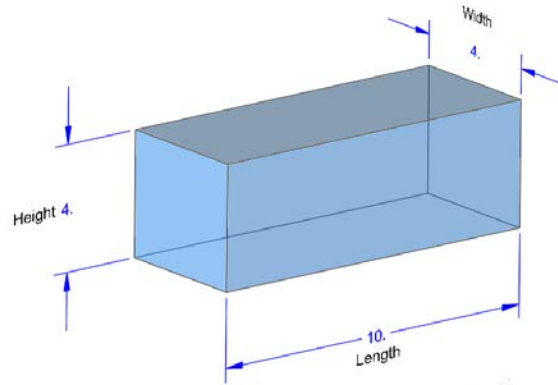

**Overall Competition Score = Workshop Score + Design report + Technical Presentation + Flight Demonstration – Penalty Points**

<b>RCA Score</b>	
<b>Description</b>	<b>Maximum Score</b>
Workshop	100
Design report	150
Technical Presentation	100
Flight Round	150
<b>Penalty for Late Submission of Design Report</b>	
For One Day	5
<b>Penalty during Oral Presentation</b>	
Oral presentation exceeds 10 minutes	25
<b>Penalty during Technical Inspection</b>	
1. Deviation from Design ( Aerodynamic Changes)	
a) 1 - 5 %	10
b) 6 - 10 %	20
c) 11 - 20 %	40
2. Structural Changes	20
3. Electronics	20
<b>Misc</b>	10
<b>Failure to Report Design Changes</b>	10

**Note : Please refer the rule book in downloads for detailed description.**

## MICRO CLASS REQUIREMENTS

Micro class will be divided into 3 phases as follows:

<b>Phase 1</b>	Design report Teams will electronically submit their Design Report for competition detailing how their design has met or exceeded the design requirements.
<b>Phase 2</b>	Technical Presentation
<b>Phase 3A</b>	Aircraft assembly Demonstration & Technical Inspection
<b>Phase 3B</b>	Flight Round

### Aircraft Requirements

1. No Lighter-Than-Air or Rotary Wing Aircraft. Competing designs are limited to fixed wing aircraft with wheels only.
2. Micro Class aircraft (MCA) should not weigh more than 1.5 kg excluding payload.
3. Timed aircraft Assembly demonstration for Round 1 is optional. If the aircraft is not assembled within the specified time, the assembly demonstration bonus will be zeroed, and the team will have the option to move to the back of the line, finish assembly, and attempt a Round 1 flight.
4. Micro class aircraft are restricted to electric motor propulsion only.
5. The maximum flight battery pack allowed for Micro class is a 3 cell lithium polymer battery pack. Batteries having less cells are also permitted.
6. Payload Bay Dimensions:

A “Closed” payload bay is defined as having four sides, a bottom and a top. The top can be a hatch or the wing once installed on the aircraft. The payload bay must be fully enclosed within the fuselage and the aircraft must be structurally airworthy with and without the payload installed

Length	Width	Height	Tolerance
5.00"	1.50"	1.50"	+/- 0.100"

7. The use of lead in any portion of the aircraft (payload included) is strictly prohibited.

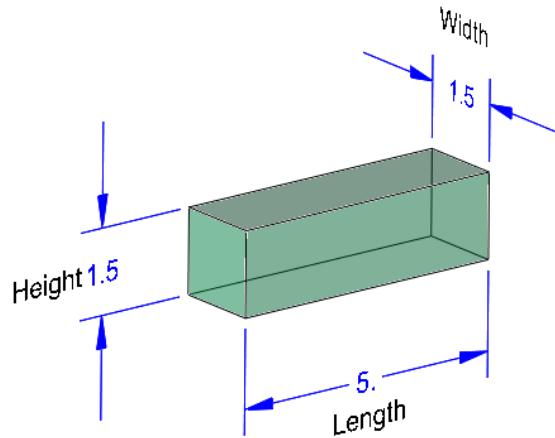

8. The MCA shall be hand tossed (launched) by throwing the aircraft using one (1) hand grasping the fuselage.

9. The aircraft container shall be of height, width & length to less than 3feet cubic / cuboid box. The fully packed aircraft system container shall weigh no more than four and a half (4.5) kilo gram (kg).

10. Micro class aircraft should be assembled prior to entering the launch zone. Each team will have 120 seconds to complete preflight checks, energize the propulsion system, and check the controls and hand-launch the aircraft. Only one takeoff launch attempt is permitted per round. If the team exceeds 120 seconds penalty points will be incurred in flight round score.

11. Takeoff for Micro class is defined as the point at which the aircraft departs the hand of the person throwing the aircraft.

12. Landing is defined as occurring from initial touchdown to the point at which the aircraft stops moving. Initial touchdown is defined as the point at which any part of the aircraft touches the ground.

<b>MCA Score</b>	
<b>Description</b>	<b>Maximum Score</b>
Workshop	100
Design report	150
Technical Presentation	100
Aircraft assembly Demonstration	50
Flight Round	100

<b>Penalty for Late Submission of Design Report</b>	
For One Day	5
<b>Penalty during Oral Presentation</b>	
Oral presentation exceeds 10 minutes	25
<b>Penalty during Technical Inspection</b>	
1. Deviation from Design ( Aerodynamic Changes)	
a) 1 - 5 %	10
b) 6 - 10 %	20
c) 11 - 20 %	40
2. Structural Changes	20
3. Electronics	20
Misc	10
<b>Failure to Report Design Changes</b>	10

**Note : Please refer the rule book in downloads for detailed description.**

**Time Limits and Multiple Flight Attempts:**

1. Multiple takeoff attempts are allowed for RCA within the time limit as long as the aircraft has NOT become airborne during an aborted attempt.

2. If an airborne aircraft returns to the ground after airborne and beyond the take-off limits, the flight attempt will be disqualified for that round.

**Table 3.1**

Class	Time Limit (sec)	Can make multiple takeoff attempts if:			Definition of Takeoff is defined as the point at which:
		Still within the Time Limit	Bounce within required take-off distance	Bounce outside the required take-off distance	
Regular	180	Yes	Yes	No	The main wheels leave the ground
Micro	120	No	No	No	The launcher is no longer in contact with the aircraft